

**New!**

## Black Tamarack Flexure Joint®

Now you can choose from white **or** black Model 740 & 742 Tamaracks!



A cosmetically appealing option for black thermoplastic and carbon fiber braces.

## Tamarack® Hex Driver



- Useful for installing the adjustment screws on Tamarack Flexure Joints®.
- Available in 2 and 2.5mm options

Part # T-740-4 (Choose large, medium or pediatric size)

## Tamarack® Spanner Wrench

- Useful tool to help align the flange nut for easier installation of dorsiflexion assist joints.
- Useful to aid disassembly of joints previously installed with thread locking compound.



Part # T-740-3 (choose large, medium or pediatric size)

## Tamarack Flexure Joint® Caps

A uniquely designed external mounting option for Tamarack Flexure Joints. Effective for both thermoplastic and carbon fiber applications

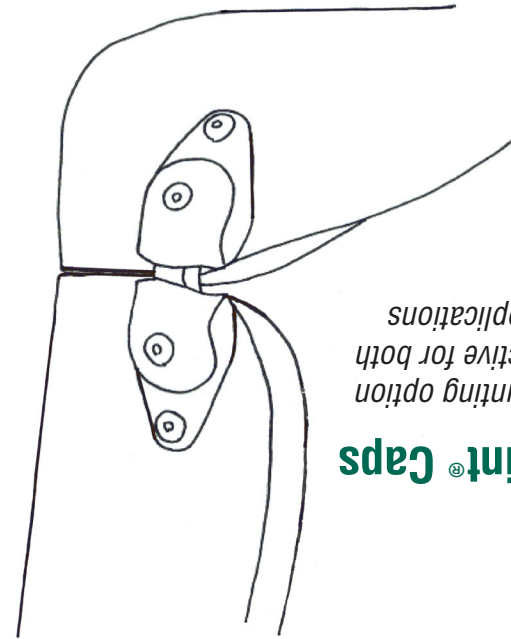

### PACKAGE CONTENTS

- 2 - Flexure Joint Caps number 1
- 2 - Flexure Joint Caps number 2
- 4 - ShearBar® flange nut cover patches
- 4 - 4mm x 0.7 stainless screws 10 mm
- 4 - 4mm x 0.7 stainless screws 6 mm
- 4 - Brass flange nuts, short barrel
- 4 - Black flange nuts, long barrel
- 2 - Drill Guides



## How to purchase Tamarack® products:

### Contact Becker Orthopedic

(800) 521-2192 toll free  
(248) 588-7480

For a list of distributors worldwide, visit:

**BeckerOrthopedic.com**

© 2011 Tamarack Habilitation Technologies  
Rev. 1 - 01/11 Manufactured in the U.S.A.



## Tamarack Flexure Joint® Caps

741-CAP-L

741-CAP-LB

**www.tamarackhti.com**

Manufactured in the U.S.A.

1. All Flexure Joint Caps are labeled with either a number 1 or a number 2 (**Fig. A**). Each Tamarack Flexure Joint must be assembled with one number 1 cap and one number 2 cap.

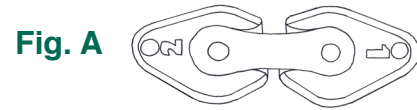

2. All Flexure Joint Caps also have a directional arrow. All directional arrows must point towards the anterior of the orthosis (**Fig. B**).

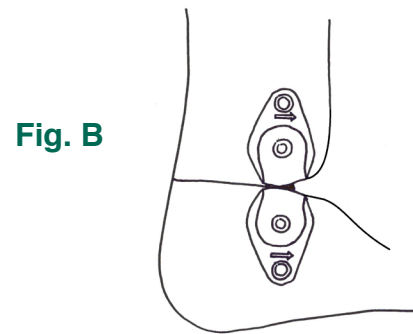

3. The Flexure Joint Caps require 4 anchoring holes on each side of the orthosis. Use the included Drill Guide to locate these holes and help locate trim lines.

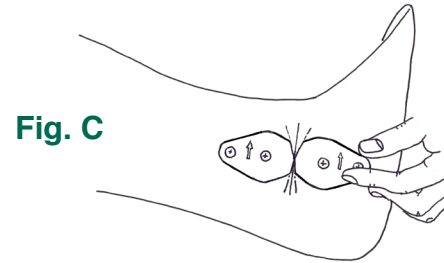

4. Position the Drill Guide so that the midpoint is located on the desired axis of joint motion and the trim line rays are correctly positioned (**Fig. C**). Mark each anchoring hole location, the midpoint and required trim lines.

**Fig. D**

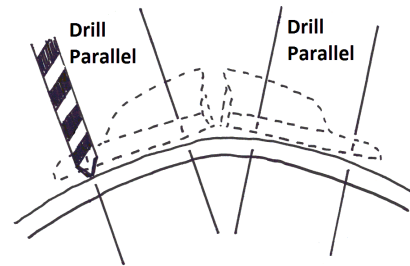

5. Use a 3/32 of an inch (2.5 mm) pilot drill to accurately locate two anchoring holes for each cap. Drill all anchoring holes to a final size of 7/32 of an inch (5.5 mm), making sure the holes for each Flexure Joint Cap remain parallel (**Fig. D**).

6. Using a thin-bladed saw (a fine toothed coping saw is the best) separate the orthosis into two sections (**Fig. E**).

**Fig. E**

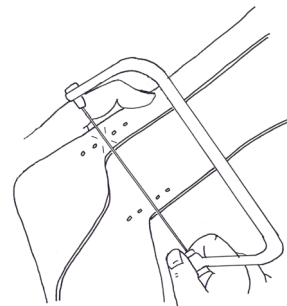

7. Using your previous trim line marks as a guide, remove material anterior or posterior of the anchoring holes to allow for the desired range of motion. Leave the narrowest possible trim line gap to provide sufficient material for properly mounting the Flexure Joint Caps (**Fig. F**).

**Fig. F**

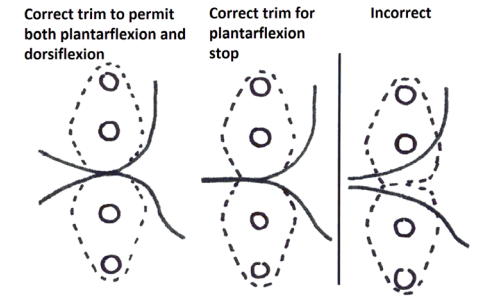

8. The longer stainless steel anchoring screws and black flange nuts should be used to secure the thicker part of each assembly. The brass flange nuts are to be used with the shorter stainless steel anchoring screws (**Fig. G**). These screws must not protrude inside the orthosis; different screw lengths are available to accommodate different thicknesses of materials.

**Fig. G**

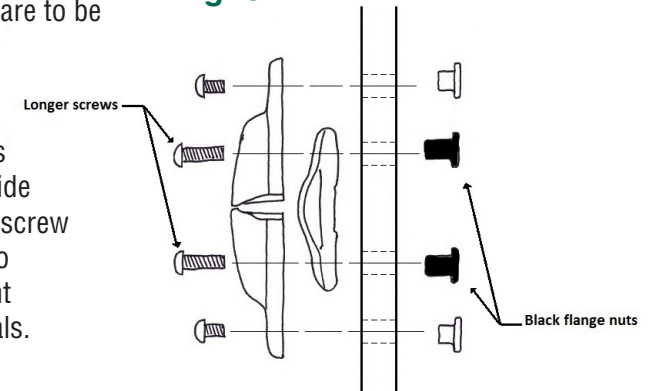

9. The flange nut heads typically protrude into the interior of the orthosis by 1/16 of an inch (1.6 mm). Recess if needed by counter-boring or heat-sinking.

10. Use a removable thread locking compound (Loctite® Threadlocker Blue 242® or equivalent) on all anchoring screws.

11. ShearBan® flange nut cover patches may be placed over the flange nuts. Each patch should cover two flange nuts (**Fig. H**).

**Fig. H**

