

## Tamarack Variable Assist™ Fabrication Instructions

**Note: The cavities created by the molding dummies may be used to install components for either dorsiflexion or plantar flexion assist.**

### 1. Components:

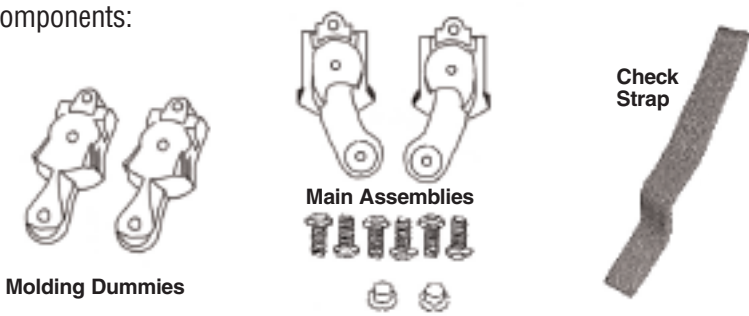

2. Pull thin/sheer stockinette over the positive mold per your usual practice.

3. Position each molding dummy on/near the axis of joint motion and fix in place with the supplied nails. Plaster or molding putty may be required to eliminate gapping between the dummy and the positive model. (**Do not** mold over the actual Tamarack Variable Assist™ joint hardware.)



4. If using the flange nuts to anchor the check strap, be sure to create a recess/countersink for the flange.

5. **DO NOT** pull any stockinette over top of the molding dummy.

6. Vacuum form or laminate as usual. Use an awl to mark the six anchoring screw hole locations.

7. After removing the shell from the model, use a thin-bladed saw to separate the foot section from the calf section.



8. Carefully grind down the surfaces as outlined in the figure to the right, to maintain maximal coverage of plastic over Tamarack Variable Assist™ joint components.

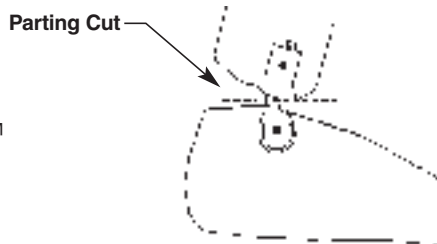

9. Use a deburring tool to round the edges of the Tamarack Variable Assist™ cavity. Create precisely located holes for the anchoring screws.  
**Large - 4.5mm (3/16 inch) clearance hole.**  
**Pediatric - 4mm (5/32 inch) clearance hole.**



10. A small hole must be drilled or punched (3/16", #12, or 5mm) to provide access to the adjustment screw. The Tamarack Variable Assist™ units are pre-assembled for posterior access. The units may be re-assembled with the adjustment screw reversed for anterior access.

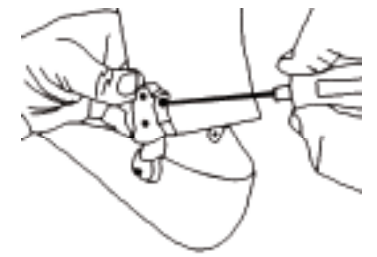

11. Install Tamarack Variable Assist Joints™ with the anchoring screws.

**Use a removable thread-locking compound** on the screws.

Note: If you need a different screw length or head style than what is provided, contact your distributor or the Tamarack website regarding information on availability of alternatives ([www.oandp.com/products/tamarack](http://www.oandp.com/products/tamarack)).

**Please note: Before adjusting amount of assist, loosen this screw and retighten after adjustment is completed.**

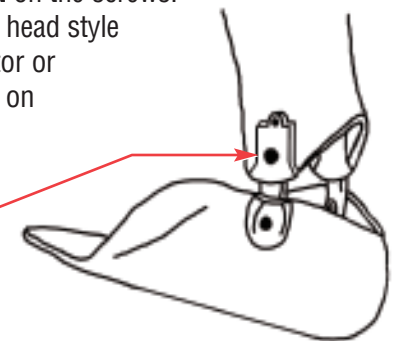

12. Attach check strap if required. A strap is provided.

#### Note of Warning:

- In most cases, use of a check strap is required. Unchecked joint motion assist can cause pain and/or tissue trauma, especially at higher levels of assist moment.
- The check strap should allow the orthosis no more than 20° of dorsiflexion when ankle dorsiflexion range of motion is normal.
- If the patient's ankle dorsiflexion range is less than normal, the check strap should restrict orthosis dorsiflexion to less than the patient's passive range.
- If the Tamarack Variable Assist™ units are used for knee, elbow, or wrist motion assist, it may be useful to make the check strap length easily adjustable.

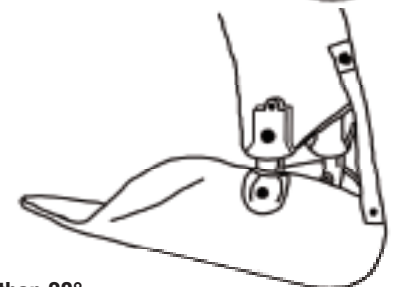

### Tamarack Variable Assist™ Moment Chart

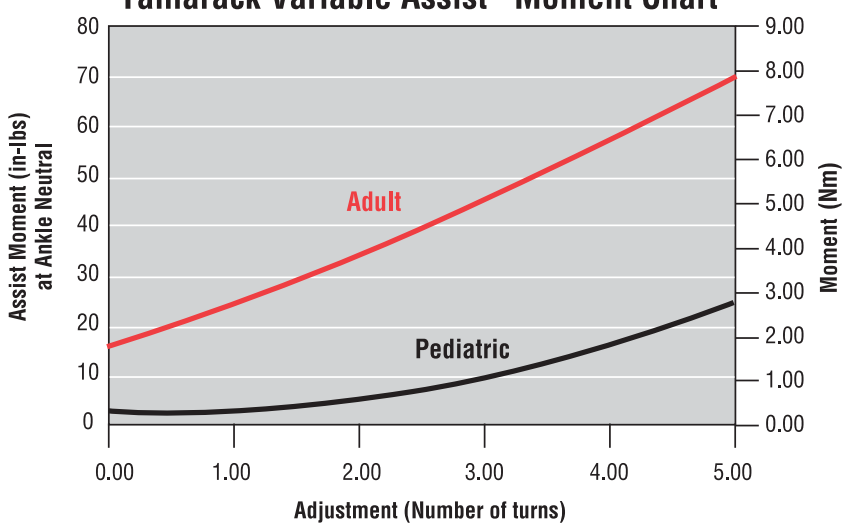

#### Note:

- Zero turns corresponds to minimum dorsiflexion assist; any adjustment from this location increases the moment of assist according to the chart above.
- Five turns corresponds to a 45° change in the angle of the joint end cap.
- All moment values correspond to the assist provided after an initial break-in period of 25 cycles.

### Tamarack Variable Assist™ for Knee and Elbow Use

When greater adjustability or angular range of motion is required, the Tamarack Variable Assist™ assembly may be doubled up as shown on the right.



### Tamarack Hand Punch

- Faster, easier and safer than drilling holes
- Precise hole location



### ShearBan™ Cosmetic Patches

For Your AFOs

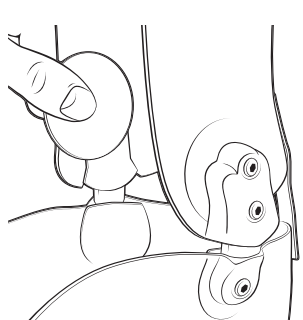

**Tamarack**  
HABILITATION TECHNOLOGIES, INC.

### Variable Assist™

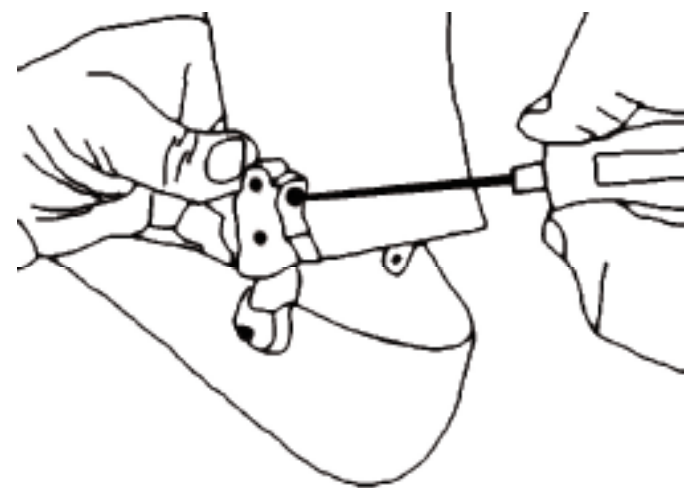

**Tamarack**  
HABILITATION TECHNOLOGIES, INC.

### Tamarack Variable Assist™

- 743-L Adult
- 743-P Pediatric

Order through Becker Orthopedic:  
Exclusive World Wide Distributor

**1-800-521-2192**

[www.beckerorthopedic.com](http://www.beckerorthopedic.com)

REV. 12/05/06

PATENT NOS. 5,826,304, D385,358, & 6,824,523  
FRANCE, GERMANY, U.K., U.S.A.  
ADDITIONAL EC PATENTS PENDING

[www.oandp.com/tamarack](http://www.oandp.com/tamarack)

MADE IN THE U.S.A. **CE**